

FV-AL81

嵌入式多合一微波氣炸蒸烤焗爐
Built-in-All-In-One Oven with Microwave



FV-AL81



金屬網架 Wire Rack /
烤盤 Baking Tray /
蒸盤 Steam Tray /
氣炸盤 Air Fry Tray



SPECIFICATIONS 規格

Model Name	型號名稱	FV-AL81
Gross Dimensions [mm]	總尺寸[毫米]	W595 x D555 x H455
Weight [kg]	重量[千克]	35
Rated Power Consumption [watts]	額定功率[瓦特]	3200 15A獨立插座 15A single phase connection
Temperature Range [°C]	可調節溫度	50-150 (蒸煮 Steam) 50-250 (烘焙 Bake) 120-230 (氣炸 Air Frying) 80-230 (微波爐 Microwave Oven)
Display	顯示	LED Display
No. of Rack Position	層架的側面滑槽	3
Function	功能	28 *包括輔助 *including auxiliary
Oven Capacity [L]	機內容量[升]	46
Water Tank Type/ Capacity[m]	水箱型/ 容量[毫升]	1200
Integrated Cleaning System	整合清潔系統	Steam Clean 蒸氣清潔

CUT-OUT DIMENSIONS & REPLACEMENT SIZE [mm] 開孔和替換尺寸 [毫米]

Cut-out Dimensions 開孔尺寸 W560 x D540 x H450

INSTALLATIONS 安裝

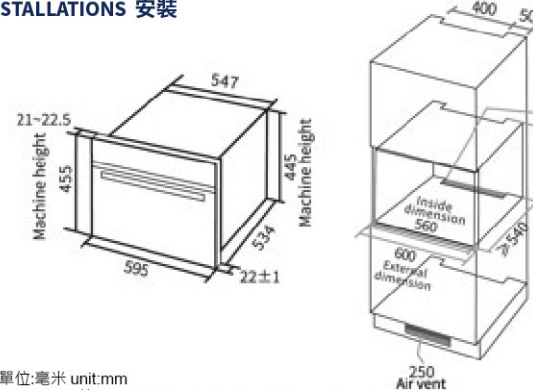

通風口
- 通風口的位置和面積變化範圍很大, 安裝方式靈活多樣。
- 通風口用於防止烤箱內部空氣不流通, 確保良好的通風。此外, 還可以加裝一小塊網狀物, 防止蟑螂和其他害蟲進入。

Air vent
- The placement and area of air vents can vary widely, allowing for flexible installation options.
- air vents are used to prevent the oven from becoming stuffy, allowing for proper ventilation. Additionally, a small piece for mesh can be added to prevent cockroaches and other pests from entering.

單位: 毫米 unit: mm
圖示並不是按比例繪畫 Illustration is not drawn to scale

產品圖像僅用於說明, 可能與實際產品有所不同。
Product images are for illustrative purposes only and may differ from the actual product.

優越功能 ADVANCED FUNCTIONS

01/ 烹飪功能多合一
All-in-One Essential Cooking Functions

提升加熱效率, 均勻煮食。
Enhances thermal efficiency for even cooking.



02/ 雙對流風扇
DUAL CONVECTION FANS

上下加熱元件可獨立調節, 實現精準烹飪控制。
Separate settings for top and bottom heating elements for precise cooking control.



03/ 雙溫控
DUAL TEMPERATURE CONTROL

氣炸鍋和蒸籠是無油健康烹飪的選擇。
Air fry and steam fry options for healthier cooking without oil.



04/ 自動烹飪菜單
AUTO COOK MENU

30 種完美烹飪方法—只需輕觸按鈕即可完成。
30 Ways to Perfect Meals — All at the Touch of a Button.



05/ 三層玻璃門
TRIPLE LAYERED GLASS DOOR

降低烤箱溫度, 營造更涼爽的環境。
Reduces heat from the oven for a cooler surrounding.



06/ 可拆卸水箱
DETACHABLE WATER TANK

幾分鐘內即可加水, 烹飪無需暫停。
Refill in Seconds, Cook Without Pause.



07/ 藍色陶瓷塗層
BLUE CERAMIC COATING

持久潔淨, 經久耐用。
Refined Clean for a Lifetime of Use.

